

extensive range
leading brands
design & install

SAFE & SECURE
ONLINE SHOPPING

australia wide authorised catering equipment distributor

Visit Australia's leading Commercial Catering Equipment website for instant quotes on the major catering equipment brands at very competitive prices.

www.mvocateringsolutions.com.au

Showroom locations

MVO Services
3 Toonburra Street
Bundaberg QLD 4670
Ph (07) 4152 7277

MVO Services
5/85 Beach Road
Hervey Bay QLD 4655
Ph (07) 4194 0722

Your requested document is included below



food warmers

food warmers

MODELS: WPIM60

APPLICATIONS

- Displays and maintains food (pies, sausage rolls, pastries etc) at serving temperature

CAPACITY GUIDE

- Holds approximately 60 to 80 pies

STANDARD FEATURES

- Toughened glass & sliding doors to front & rear & toughened glass side panels
- Black powder-coated finish
- Removable stainless steel crumb tray
- Thermostat controls
- Illuminated front lightbox display
- Fully illuminated interior for improved product display
- Supplied with 4 tilting chrome wire racks
- Cleanable stainless steel element guard for safety & aesthetics
- Visible temperature gauge
- Humidity tray provided to maintain product quality
- Supplied with 10 amp plug and lead

SPECIFICATIONS

Kw 1.68 Amps 7		
Width 640	Depth 460	Height 645

Dealer:



Model shown WPIM60

WPIM60

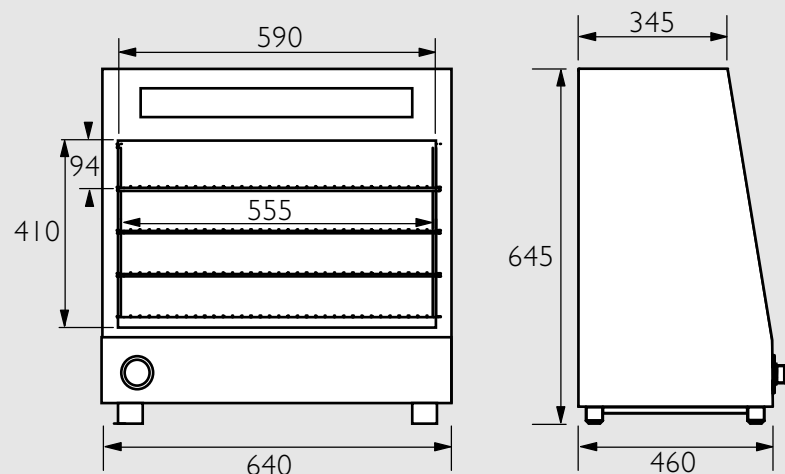

⚡ Power cable located at back left hand side of unit

We reserve the right to alter specifications of products without notice

For details of your local dealer contact:

QLD, NT, WA, International ph 07 3344 2444 fax 07 3345 6403 email fse@stoddart.com.au	NSW, ACT ph 02 9817 7700 fax 02 9817 7800 email gladesville@stoddart.com.au	VIC, SA, TAS ph 03 9543 9922 fax 03 9543 9944 email melbourne@stoddart.com.au
---	---	---

Manufactured by: Tom Stoddart Pty Ltd, 215 Jackson Road Sunnybank Hills, Qld 4109 Australia