

extensive range
leading brands
design & install

SAFE & SECURE
ONLINE SHOPPING

australia wide authorised catering equipment distributor

Visit Australia's leading Commercial Catering Equipment website for instant quotes on the major catering equipment brands at very competitive prices.

www.mvocateringsolutions.com.au

Showroom locations

MVO Services
3 Toonburra Street
Bundaberg QLD 4670
Ph (07) 4152 7277

MVO Services
5/85 Beach Road
Hervey Bay QLD 4655
Ph (07) 4194 0722

Your requested document is included below



chicken display

MODELS: WPHC.23

- Fan forced humidified display cabinet specifically for merchandising chickens or roast meat
- Keeps product at compliant temperatures whilst reducing moisture loss
- Gastronorm sized well (GN 1/1)
- Toughened front curved glass and toughened rear sliding doors with stainless steel rollers
- Overhead halogen heat lamps
- Multiple element design
- Option of illuminated light box for product advertising
- Utilise with optional wire mid shelves for additional storage space
- Pans and mid-shelves sold separately



WPHC.23

We reserve the right to alter specifications of products without notice

SPECIFICATIONS:

Kw 2.1 W 1150 D 800 H 660

Dealer:

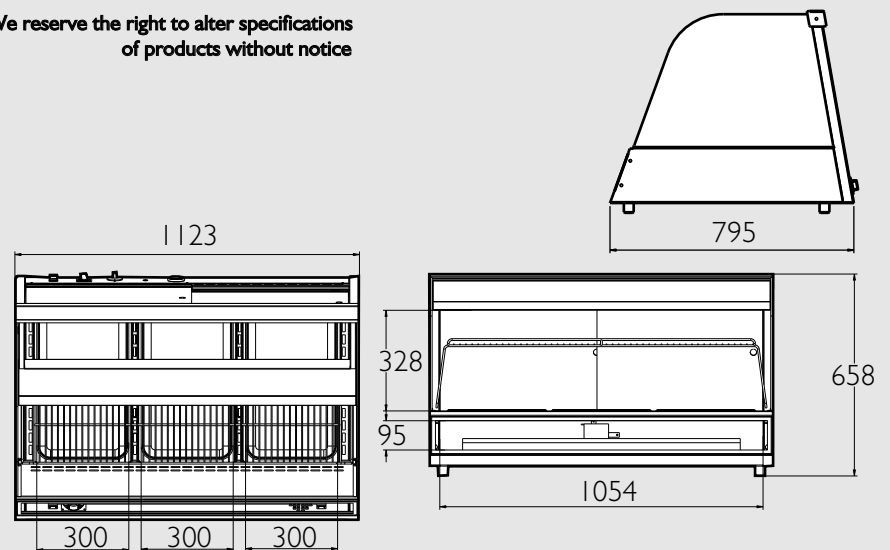

For details of your local dealer contact:

QLD, NT, WA, International
ph 07 3344 2444 fax 07 3345 6403
email fse@stoddart.com.au

NSW, ACT
ph 02 9817 7700 fax 02 9817 7800
email gladesville@stoddart.com.au

VIC, SA, TAS
ph 03 9706 5250 fax 03 9706 5290
email melbourne@stoddart.com.au