

extensive range
leading brands
design & install

SAFE & SECURE
ONLINE SHOPPING

australia wide authorised catering equipment distributor

Visit Australia's leading Commercial Catering Equipment website for instant quotes on the major catering equipment brands at very competitive prices.

www.mvocateringsolutions.com.au

Showroom locations

MVO Services
3 Toonburra Street
Bundaberg QLD 4670
Ph (07) 4152 7277

MVO Services
5/85 Beach Road
Hervey Bay QLD 4655
Ph (07) 4194 0722

Your requested document is included below



UNIQUE GENTLE AIR CIRCULATION
FOR MAXIMUM PRODUCT LIFE



CUTTING EDGE DESIGN
FOR MAXIMUM IMPACT

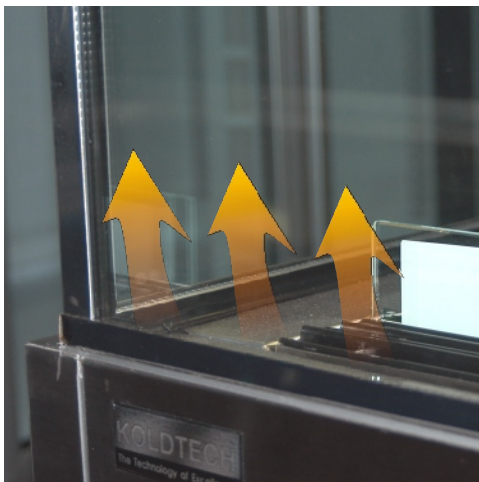

DOUBLE GLAZED SIDES & FRONT
WITH WARM AIR TO EXTERIOR
FOR BETTER VISIBILITY

DEALER:

Cake Display

SQUARE PROFILE - SQRCD SERIES



SQRCD-12

KOLDTECH
The Technology of Excellence

FRONT VIEW

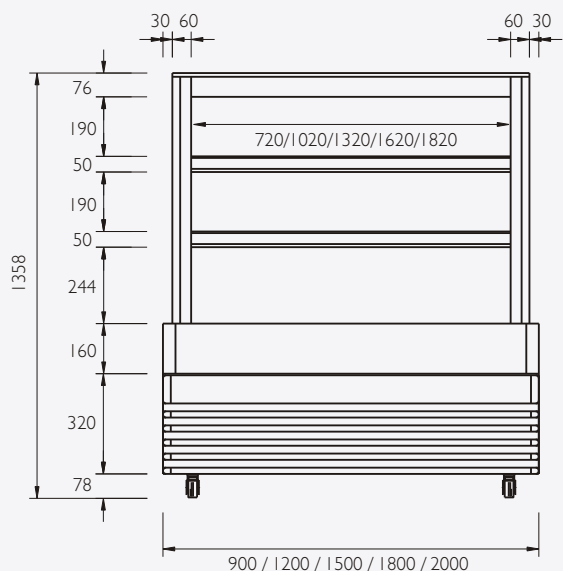

SIDE VIEW

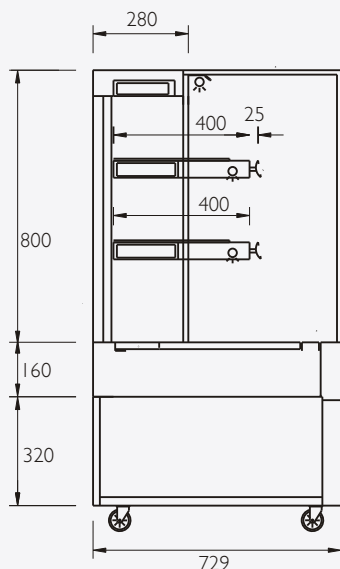

TOP VIEW

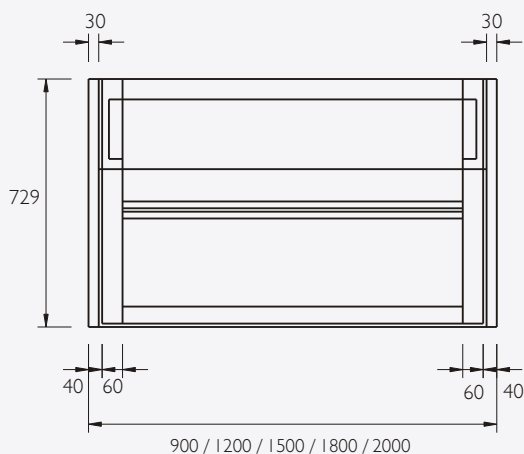

SQRCD-SERIES SQUARE CAKE DISPLAYS

PERFORMANCE & OPERATING CONDITIONS

SQRCD series cake displays are designed to hold product at below 5°C. Thermostat adjustable between 2°C & 15°C for products requiring different holding temperatures. SQRCD cabinets are rated to operate at ambient temperatures up to 32°C. Front & side glass panels are guaranteed to remain condensation free at 70% relative humidity.

STANDARD FEATURES

REFRIGERATION SYSTEM

Uniquely designed gentle air circulation above each shelf. Cold air is ducted throughout the cabinet and falls gently on to the product without the use of fans. Reliable self contained, bottom mounted refrigeration system, using environmentally friendly R-134a refrigerant. All ventilation at rear of cabinet. Refrigeration system easily serviceable from removable panel at rear of unit.

CONTROLLER

Adjustable microprocessor control with digital temperature display. Separate power & light switches

BODY & FURNISHING

Double glazed "Low-E" straight glass front & sides with warm air directed up front of unit to prevent condensation. Top of display section is made from 10mm glass. Self closing double glazed sliding doors to rear with one way mirror finish (SQRCD9 equipped with double glazed rear swinging doors.) All external panels are fully insulated and finished with satin finished 304 grade stainless steel on exterior faces. All internal surfaces are 304 grade stainless steel. Stainless top - rear serving shelf. Supplied on 78mm castors for ease of cleaning.

SHELVES

3 fixed display shelves, each illuminated with high impact lighting. Shelves constructed from stainless steel & covered with glass, to prevent scratching & for ease of cleaning. Ticket stripping provided for top two shelves for improved product merchandising.

OPTIONS

Heated double glazed glass all around display case, (excluding rear doors) with separate controls.

WARRANTY

12 months onsite parts & labour.

TECHNICAL DATA

SQRCD-9

Watts 840
Cooling capacity (Btu) / Compressor (Hp) 1910 / 1/2

SQRCD-12

Watts 912
Cooling capacity (Btu) / Compressor (Hp) 1910 / 3/4

SQRCD-15

Watts 960
Cooling capacity (Btu) / Compressor (Hp) 2729 / 3/4

SQRCD-18

Watts 1320
Cooling capacity (Btu) / Compressor (Hp) 4435 / 1

SQRCD-20

Watts 1320
Cooling capacity (Btu) / Compressor (Hp) 4435 / 1

Continued product improvement is **WELBUILT** Manufacturing Ltd policy. Specifications are subject to change without notice

MANUFACTURED BY WELBUILT MANUFACTURING LTD.

IMPORTED BY TOM STODDART PTY LTD,

215 JACKSON ROAD SUNNYBANK HILLS QLD 4109

WARRANTY & SERVICE ENQUIRIES: (07) 3344 2444 FAX: (07) 3345 6403

KOLDTECH
The Technology of Excellence

