

extensive range
leading brands
design & install

SAFE & SECURE
ONLINE SHOPPING

australia wide authorised catering equipment distributor

Visit Australia's leading Commercial Catering Equipment website for instant quotes on the major catering equipment brands at very competitive prices.

www.mvocateringsolutions.com.au

Showroom locations

MVO Services
3 Toonburra Street
Bundaberg QLD 4670
Ph (07) 4152 7277

MVO Services
5/85 Beach Road
Hervey Bay QLD 4655
Ph (07) 4194 0722

Your requested document is included below



Display Case

REFRIGERATED DISPLAY CASE - RCD SERIES

High-Impact Lighting
under each shelf for
optimum illumination

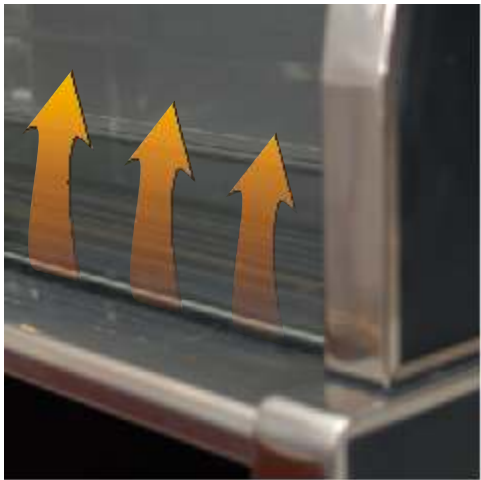

Warm air directed
up front of unit
to prevent condensation



Exceptional refrigeration
performance keeps cakes
looking better for longer



DEALER:



Front View

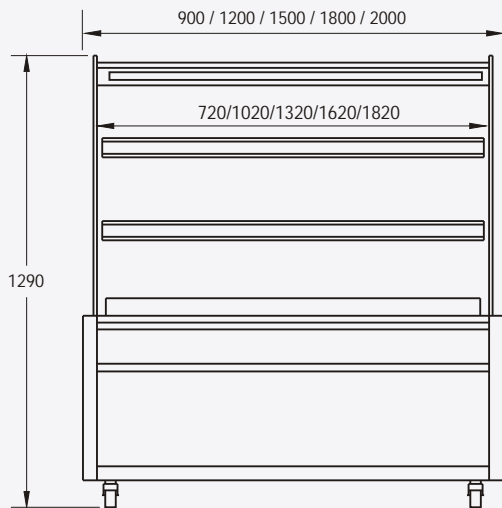

Side View

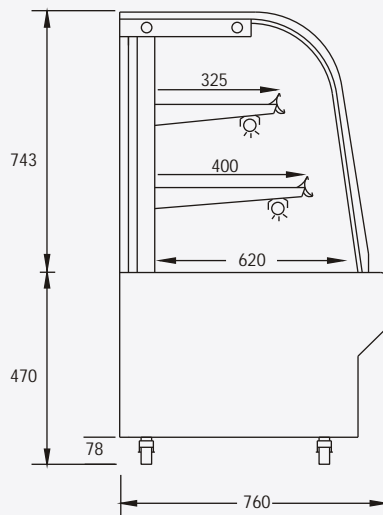

Top View

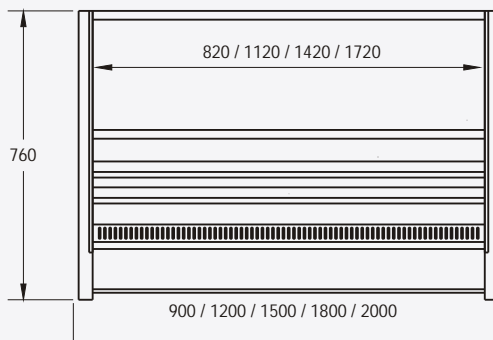

Matching hot units available - ask about our HCD series

RCD-SERIES

curved display case

Performance and operating conditions

RCD series cake displays are designed to hold products at below 5°C. Thermostat adjustable between 2°C & 15°C for products requiring different holding temperatures. The RCD series cake display are rated to operate at ambient temperatures up to 32°C. Glass is guaranteed to remain free of condensation at up to 70% relative humidity.

Standard Features

Refrigeration system

Reliable self contained, bottom mounted refrigeration system using environmentally friendly R134a refrigerant. All ventilation at rear of cabinet. Refrigeration system easily serviceable from removable panel at rear of unit. No drainage connection required.

Controller

Microprocessor controlled with adjustable digital temperature display. Separate power and light switches.

Body & furnishing

Double glazed curved front glass with warm air directed up front of unit to prevent condensation. Self closing double glazed sliding rear doors with one way mirror finish (RCD-9 equipped with double glazed rear swinging doors.) Steel frame for extra strength. Insulated exterior powdercoated panels finished in matt black. All internal surfaces are bright polished 304 grade stainless steel. Glass top rear serving shelf. Supplied on 78mm removable castors for ease of cleaning. Exterior cabinet trim finished with bright polished 304 grade stainless steel.

Shelves

3 glass display shelves, each with illuminated with high impact lighting. Top two shelves fully adjustable with ticket stripping provided for improved product merchandising.

Warranty

12 months onsite parts & labour.

Technical Data

Rcd - 9

Watts 504
Cooling capacity (Btu) Compressor (Hp) 1910 / 1/2

Rcd - 12

Watts 600
Cooling capacity (Btu) Compressor (Hp) 1910 / 1/2

Rcd - 15

Watts 1008
Cooling capacity (Btu) / Compressor (Hp) 2729 / 3/4

Rcd - 18

Watts 1512
Cooling capacity (Btu) / Compressor (Hp) 4435 / 1

Rcd - 20

Watts 1512
Cooling capacity (Btu) / Compressor (Hp) 4435 / 1

Continued product improvement is WELBILT Manufacturing Ltd policy. Specifications are subject to change without notice

Manufactured by Welbilt Manufacturing Ltd.
Imported by Tom Stoddart Pty Ltd,
215 Jackson Road Sunnybank Hills Qld 4109
Warranty, Service & dealer enquiries:
(07) 3344 2444 Fax: (07) 3345 6403

