



Visit Australia's leading Commercial Catering Equipment website for instant quotes on the major catering equipment brands at very competitive prices.

[www.mvocateringsolutions.com.au](http://www.mvocateringsolutions.com.au)

#### Showroom locations

MVO Services  
3 Toonburra Street  
Bundaberg QLD 4670  
Ph (07) 4152 7277

MVO Services  
5/85 Beach Road  
Hervey Bay QLD 4655  
Ph (07) 4194 0722

Your requested document is included below



Designed for easy installation into new or existing benches

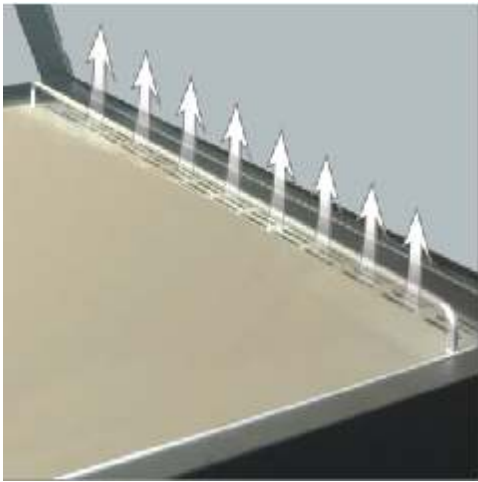

Fan forced hot or cold air operation



Height and angle adjustable shelves for optimum product display

# Countertop Display

drop-in countertop display cabinets - Refrigerated & Heated



KT.RCD.8.DI

DEALER:



## COLD UNIT (KT.RCD.8.DI)

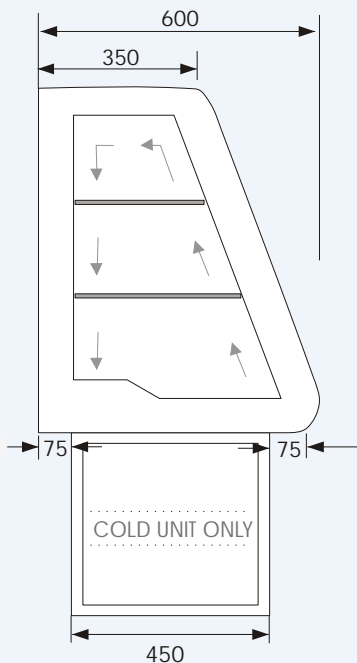
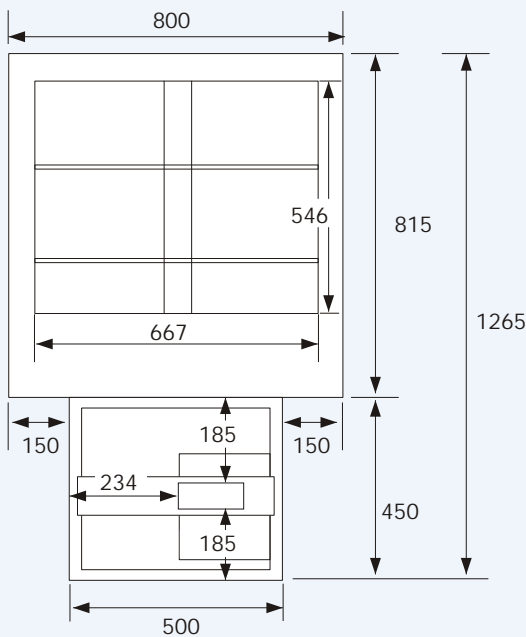

## HOT UNIT (KT.HCD.8.DI)

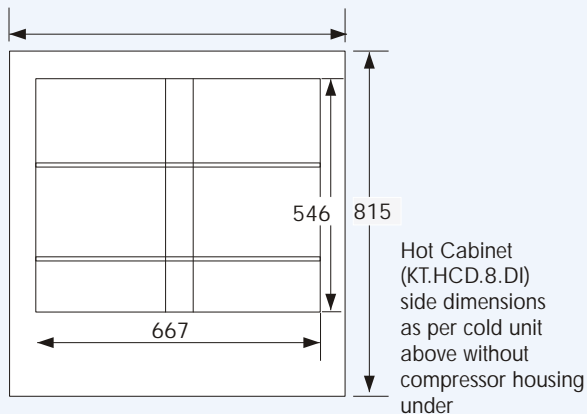

# KT.RCD.DI-SERIES

refrigerated countertop display case

## Performance & operating conditions

KT.RCD.DI series displays are designed to hold product at below 5°C. Thermostat adjustable between 0°C & 15°C for products requiring different holding temperatures. KT.RCD.DI cabinets are rated to operate at ambient temperatures up to 32°C. Designed for easy countertop installation.

## Refrigeration system

Reliable self contained, bottom mounted refrigeration system using environmentally friendly R134a refrigerant. Refrigeration system easily serviceable from removable panel at rear of unit. No drainage connection required.

## Technical Data

### KT.RCD.8.DI

Wattage	530W
Amperage	2.2Amps
Cooling capacity (Btu) / Compressor (Hp)	1910 / 1/2

# KT.HCD.DI-SERIES

heated countertop display case

## Performance & operating conditions

KT.HCD.DI series displays are designed to hold pre-heated products at serving temperatures. Thermostat adjustable between 30°C & 90°C for products requiring different holding temperatures. Designed to sit on countertop.

## Heated system

Fan forced heating system.

## Technical Data

### KT.HCD.8.DI

Wattage	1090W
Amperage	4.5Amps

## Standard Features - hot & cold displays

### Controller

Adjustable microprocessor control with digital temperature display. Separate power & light switches.

### Body & Furnishing

Double glazed "Low-E" straight glass front. Toughened glass sliding doors to rear. Toughened 6mm glass side panels. All internal surfaces are 304 grade stainless steel. Exterior metal surfaces in black powder coated steel. Fully illuminated interior.

### Shelves

Two adjustable cantilevered stainless wire shelves (730 x 230mm & 730 x 290mm). Shelves can be angled forward for improved merchandising. Ticket stripping provided as standard for shelves. Interior base in stainless steel for additional display storage.

### Warranty

12 months onsite parts & labour.

Continued product improvement is WELBUILT Manufacturing Ltd policy. Specifications are subject to change without notice

Manufactured by Wel built Manufacturing Ltd.  
Imported by Tom Stoddart Pty Ltd,  
215 Jackson Road Sunnybank Hills Qld 4109  
Warranty & Service enquiries: (07) 3344 2444 Fax: (07) 3345 6403

