

extensive range
leading brands
design & install

SAFE & SECURE
ONLINE SHOPPING

australia wide authorised catering equipment distributor

Visit Australia's leading Commercial Catering Equipment website for instant quotes on the major catering equipment brands at very competitive prices.

www.mvocateringsolutions.com.au

Showroom locations

MVO Services
3 Toonburra Street
Bundaberg QLD 4670
Ph (07) 4152 7277

MVO Services
5/85 Beach Road
Hervey Bay QLD 4655
Ph (07) 4194 0722

Your requested document is included below

Display Case

HEATED DISPLAY CASE - HCD SERIES



High-Impact Lighting
under each shelf for
optimum illumination

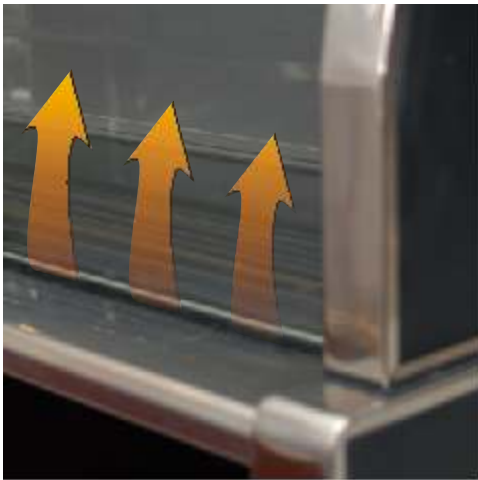

Fan forced air operation



Exceptional performance
keeps product
looking better for longer

DEALER:



KT.HCD.12

KOLDTECH

The Technology of Excellence

Front View

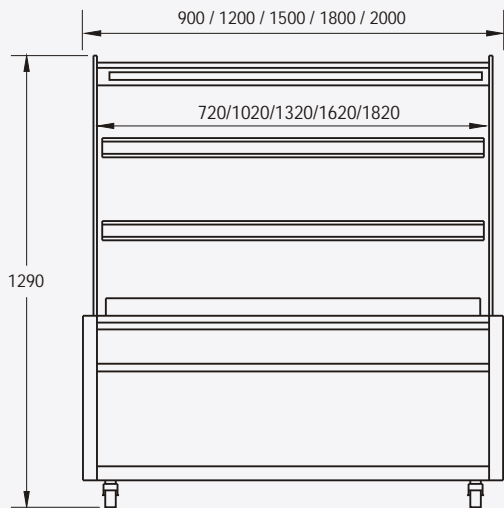

Side View

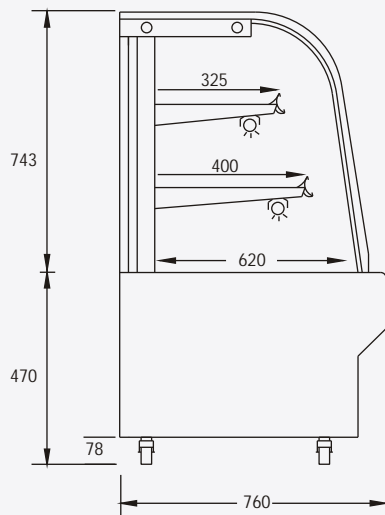

Top View

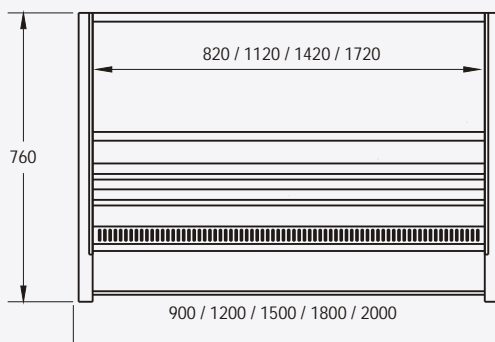

Matching cold units available - ask about our RCD series

HCD-SERIES

curved display case

Performance and operating conditions

HCD series cake displays are designed to hold pre-heated products at serving temperature. Thermostat adjustable between 60°C & 110°C for products requiring different holding temperatures.

Standard Features

Heating system

Fan forced heating system. Includes humidity tray for holding water to keep product moist.

Controller

Adjustable microprocessor control with digital temperature display. Separate power & light switches

Body & Furnishing

Curved glass front. Fully insulated side panels. Top of display section is made from 10mm glass. Double glazed sliding doors to rear. (HCD.9 equipped with double glazed rear swinging doors.) All external panels are fully insulated and finished with satin finished 304 grade stainless steel on exterior faces. All internal surfaces are 304 grade stainless steel. Stainless top - rear serving shelf. Supplied on 78mm castors for ease of cleaning.

Shelves

2 adjustable and 1 fixed display shelves. All shelves illuminated with overhead high impact lighting. Shelves constructed from stainless steel wire, to prevent scratching & for ease of cleaning. Ticket stripping provided for top two shelves for improved product merchandising.

Options

Extra shelving available (non-illuminated)

Warranty

12 months onsite parts & labour.

Technical Data

Hcd.9

Watts 1720

Supplied with 10 amp plug & lead

Hcd.12

Watts 1800

Supplied with 10 amp plug & lead

Hcd.15

Watts 1800

Supplied with 10 amp plug & lead

Continued product improvement is WELBILT Manufacturing Ltd policy. Specifications are subject to change without notice

Manufactured by Welbilt Manufacturing Ltd.
Imported by Tom Stoddart Pty Ltd,
215 Jackson Road Sunnybank Hills Qld 4109
Warranty, Service & dealer enquiries:
(07) 3344 2444 Fax: (07) 3345 6403

